

TABLE 1: ELECTRICAL SPECIFICATIONS AT 25 °C

SWITCHING TRANSFORMER DESIGNED FOR USE WITH POWER INTEGRATIONS
 TNY-255 REFER TO APPLICATION CIRCUIT OF FIGURE 3.

PARAMETER	SPEC LIMITS			UNITS
	MIN.	TYP.	MAX.	
PRIMARY INDUCTANCE (4-1) FREQ. = 100 KHZ @ 0.250Vrms	3600	4000	4400	μHY
TURNRATIO'S: SECONDARY (10-8): PRIMARY (4-1)	---	1: 18.5	---	± 4%
PRILEAKAGE IND. (10-5 SHORTED) FREQ. = 100 KHZ @ 0.250Vrms	---	---	140.0	μHY
HIPOT: PRIMARY TO SECONDARY	3000	---	---	Vrms
APP CIRCUIT PARAMETERS: (1) AC INPUT VOLTAGE	85	---	265	Vac
DCHOT RAIL VOLTAGE	110	---	375	Vdc
OUTPUT VOLTAGE	---	5.0	---	Vdc
OUTPUT CURRENT CONTINUOUS	100	---	1500	mA
LINE REGULATION (85 TO 265Vac)	---	0.50	---	±%
LOAD REGULATION 10-100%	---	0.30	---	±%
RIPPLE	---	50.0	---	±mV

(1) REFER TO APPLICATION CIRCUIT OF FIGURE 3.

FIGURE 1: SCHEMATIC DIAGRAM

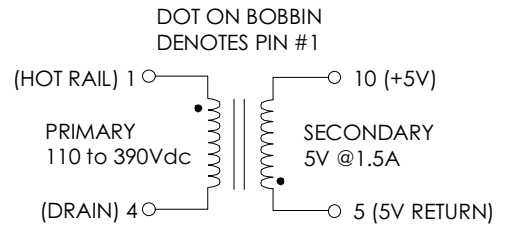

NOTE1:
REINFORCED INSULATION SYSTEM, UL1950, IEC950, CSA-950:
 A) ALL MATERIALS MEET "UL", "CSA" & "IEC" REQUIREMENTS
 B) TRIPLE INSULATED SECONDARY.
 C) ALL MATERIALS ARE RATED 130C OR BETTER
 D) DESIGNED FOR >6.2mm CREEPAGE REQUIREMENTS.
 E) VARNISH FINISHED ASSEMBLY.
 F) UL1950 & CSA-950 CERTIFIED: FILE #E162344.
 G) UL CLASS (B) 130 INSULATION SYSTEM PM130-R1,
 PM130-H1, PM130-H1A (UL FILE #E177139) OR ANY UL
 AUTHORIZED CLASS (B) INSULATION SYSTEM.

FIGURE 2: PHYSICAL DIMENSIONS mm (INCHES)

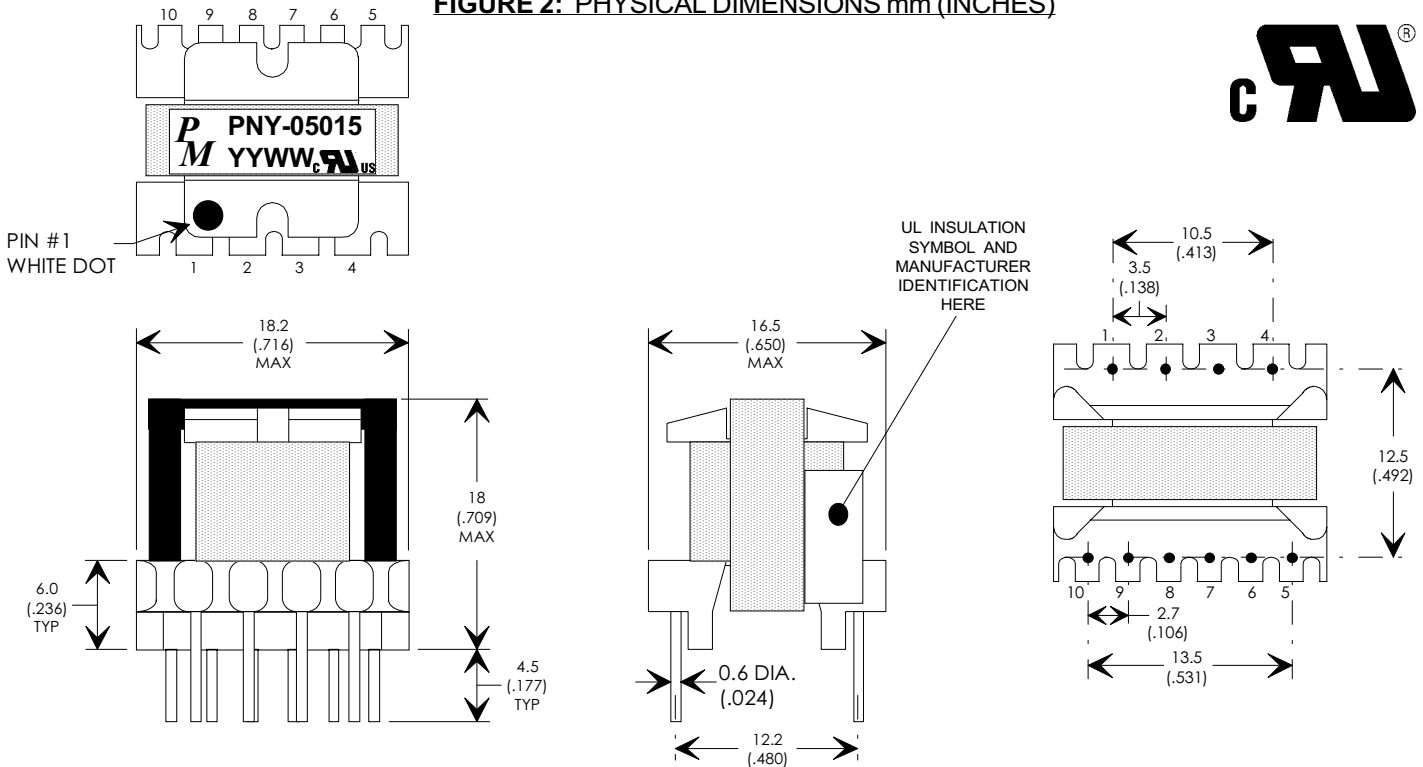

EE16/EI16, 10-PIN VERTICAL



UNLESS OTHERWISE SPECIFIED
 DIMENSIONS ARE IN MM
 DIMENSIONAL TOLERANCES ARE:
 DECIMALS ANGLES
 .X ± .25 ±0° 30'
 .XX ± .15
 DO NOT SCALE DRAWING

REV.	DESCRIPTION OF CHANGES	BY
02/10/99	ORIGINAL RELEASE	TO
02/17/99	CORRECTED SECONDARY PIN NUMBERS	TO
10/04/99	UPGRADE TO UL CLASS (B) 130 INSULATION SYSTEM	MD
01/12/00	UPDATE TO UL RECOGNIZED FILE #E162344	MD
11/30/01	CORRECTED PRI. PIN# IN PARAMETER TO (1-4) WAS (4-1)	LL

FLYBACK TRANSFORMER CONTROL DRAWING	
PREMIER P/N: PNY-05015	REVISION: 11/30/01
DRAWN BY: TOM O'NEIL	REF: TNY-255
SCALE: NONE	SHEET: 1 OF 6

APPLICATION NOTES

Premier Magnetics' PNY-05015 Switch Mode Transformer was designed for use with Power Integrations, Inc. TNY255 off-line switchmode regulator in the Flyback Buck-Boost circuit configuration. This conversion topology will provide an isolated output with efficiencies up to 90%. Premier's PNY-05015 transformer has been optimized to provide maximum power throughput.

The TNYXXX series from Power Integrations, Inc. are self contained 40 or 130KHz switching regulators. This series contains all necessary functions for an off-line switched mode control DC power source. These switching regulators provide a very simple solution to off-line low power designs less than 5W and off high volate DC Bus designs less than 10W. The inductors and transformer used with the TNYXXX are critical to the performance of the circuit. They define the overall efficiency, output power and overall physical size.

Below is a universal input high precision 7.5 watt application circuit utilizing Power Integrations TNY255 switching regulator in the flyback buck-boost configuration. The component values listed are intended for reference purposes only. Proper thermal management of the TNY255 & D1 is required for reliable operation. The TNY255 should be mounted on ≥ 0.75 in², 2oz copper clad to provide a proper heat sink starting point for evaluation. The component values listed are intended for reference purposes only. Careful evaluation by the end user is required and should be based on the actual application & it's associated environmental conditions.

FIGURE 3: TYPICAL APPLICATION CIRCUIT

PREMIER MAGNETICS PART NUMBERS:
(REQUEST DATA SHEETS BY PART#)

L1 = PMCU-5220 22mHy Miniature EMI/RFI CMC
T1 = PNY-05015 MAIN SWITCHING TRANSFORMER
L2 = VTP-01001 10uHy, 1.0Amp INDUCTOR

ALUMINUM ELECTROLYTIC FILTER CAPACITOR RATINGS:

C1 : $\geq 400V$, Ripple Rated $\geq 125mA$ @ 120Hz @ Max. Operating Temp.
(Nichicon P/N URT2G330MRA, 105C)
C2 : $\geq 10V$, Ripple Rated $\geq 1500mA$ @ 100KHz @ Max. Op. Temp.
(Panasonic P/N EEUFA1A152, 105C)
C3 : $\geq 10V$, (Panasonic P/N ECA1AFG221, 105C)

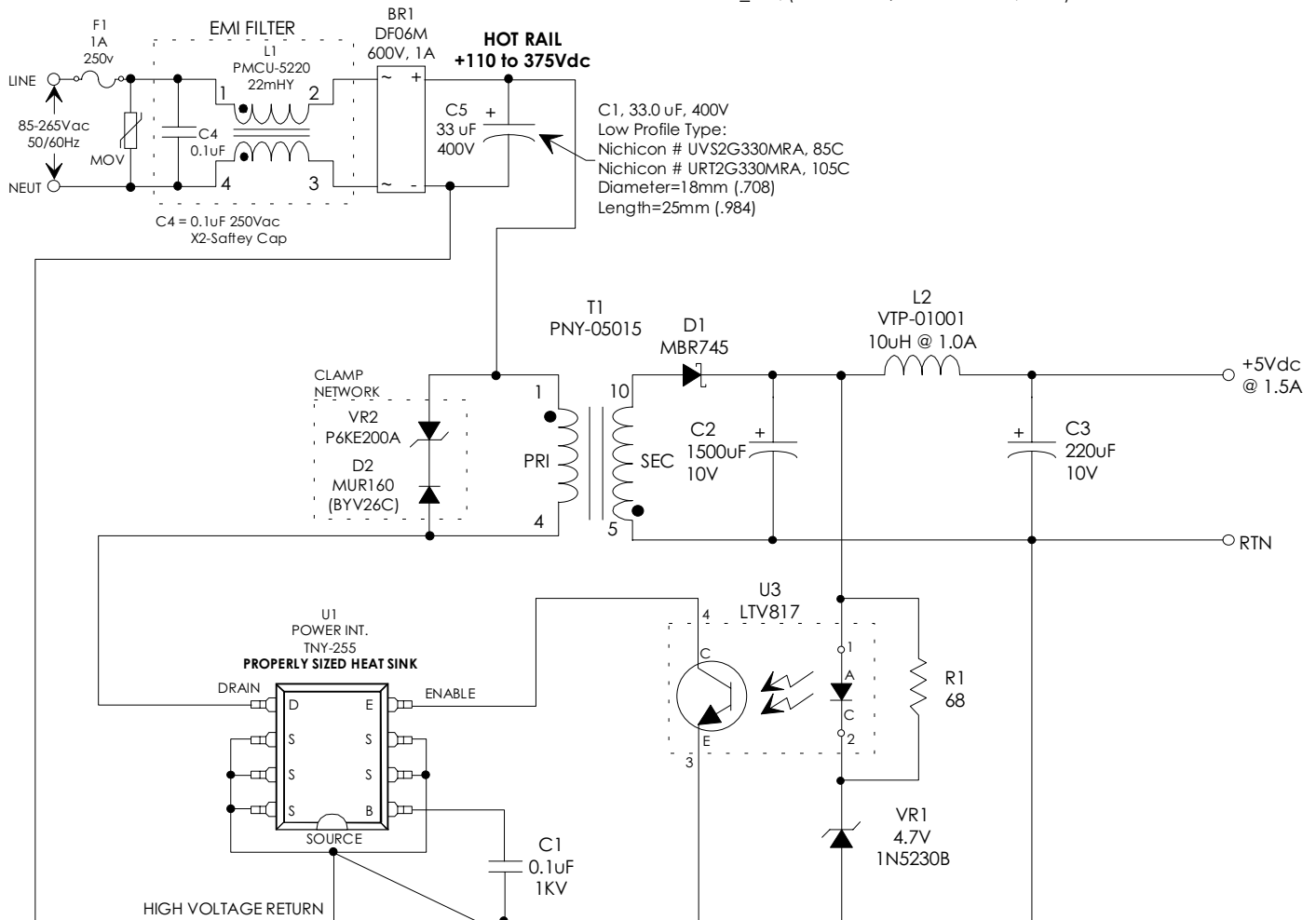

UNLESS OTHERWISE SPECIFIED
DIMENSIONS ARE IN MM
DIMENSIONAL TOLERANCES ARE:
DECIMALS ANGLES
.X $\pm .25$ $\pm 0^\circ 30'$
.XX $\pm .15$
DO NOT SCALE DRAWING

FLYBACK TRANSFORMER CONTROL DRAWING	
PREMIER P/N: PNY-05015	REVISION: 11/30/01
DRAWN BY: TOM O'NEIL	REF: TNY-255
SCALE: NONE	SHEET: 2 OF 6